

DAVID DAWNS

VOLVO

INSTRUCTION BOOK

F 88

G 88

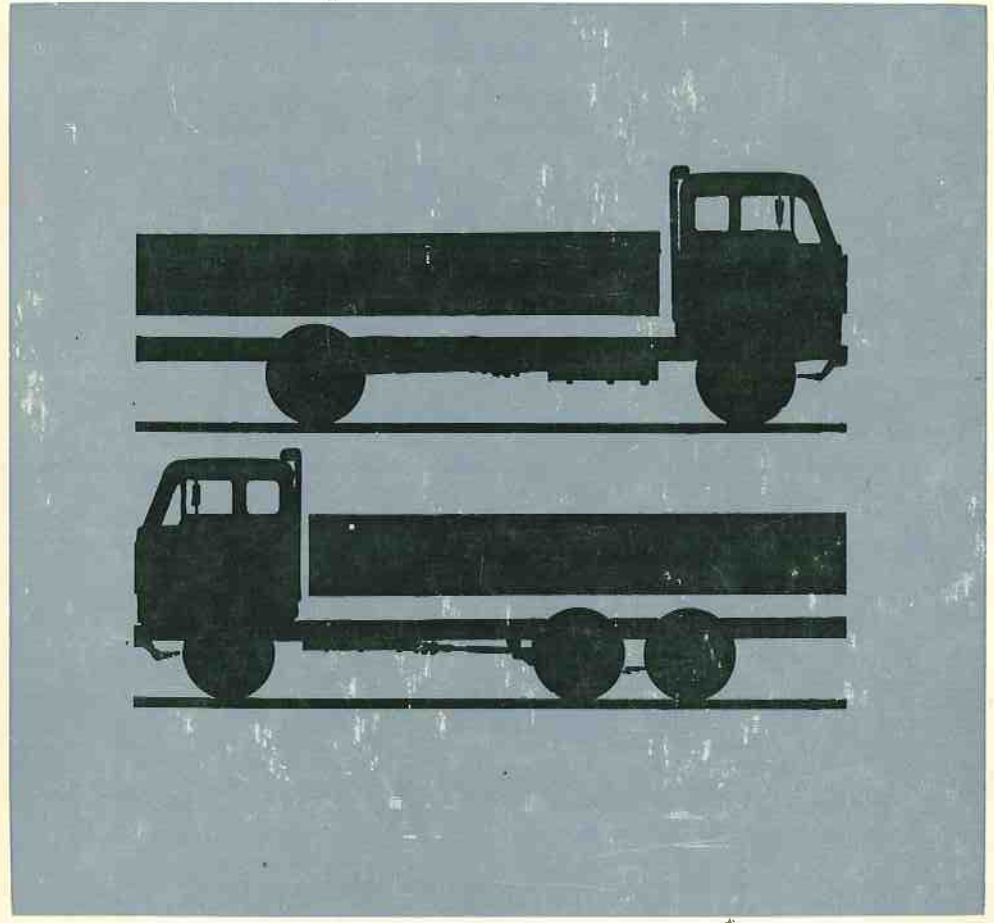

This instruction book concerns all versions of Volvo F 88 and G 88 trucks as follows:

F 88

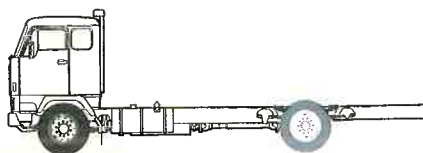

FB 88

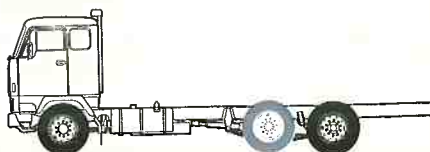

F 88 6x4 (four-wheel drive bogie)

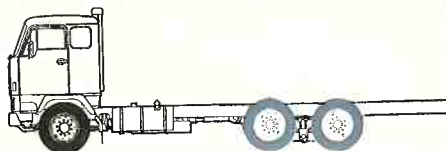

G 88 4x2

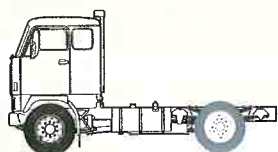

G 88 6x2

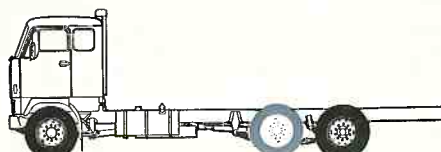

G 88 6x4 (four-wheel drive bogie)

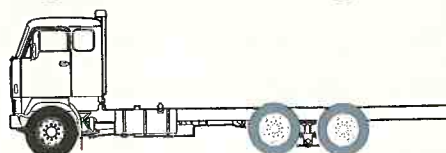

VOLVO
52 403

In the figure combinations, 4x2 etc., the first figure indicates the total number of wheels and the second figure states how many of the wheels are driven.

The main difference between the F-models and G-models is that the G-models have the front axle placed further forward.

Vehicles with four-wheel drive bogie are only available on certain markets.

The text and illustrations in the instruction book apply to all models unless otherwise stated.

This Instruction Book contains all the information you need to enable you to operate and maintain your vehicle in the best possible way.

By following the advice and instructions given in this book you will find that your truck will fulfil all demands as regards good running economy and performance which you have every right to expect from a high-quality Volvo product.

This Instruction Book is not intended to be a comprehensive technical manual, neither does it claim to make the reader a qualified motor mechanic. The purpose of the book is to provide you with information as to how the vehicle should be maintained and serviced in order to avoid operating difficulties. The better you know your vehicle, the better the service you can expect from it.

For a fuller description of working procedures and adjustments, please refer to the special Service Manual which can be purchased from the dealer. The specifications and constructional information given in this book are not binding. We reserve the right to carry out modifications without prior notification.

AB VOLVO · GÖTEBORG

May be reproduced if source quoted

Volvo Service

In order to ensure that you, as the owner of a Volvo truck, can obtain the best possible running economy, Volvo has built up an extensive service organisation. In all parts of the world where Volvo vehicles are sold there are modern and well-equipped workshops with specially trained personnel at your service.

Continuous and progressive product development work takes place at the Volvo factory. All the information and design modifications resulting from this work often require amendments to instructions concerning repairs and adjustments. These instructions are distributed as quickly as possible to all the workshops included in the Volvo service organisation. These workshops are equipped with modern machines and measuring devices, as well as special tools designed by Volvo. All Volvo dealers have well-stocked and well-organised spare parts stores, thereby ensuring you a ready supply of genuine Volvo parts. This means that Volvo dealers are in the best position to provide first-class service. Should you require any information which is not included in this book, please consult your Volvo dealer.

Inspections

A Warranty Booklet is supplied with each vehicle. This booklet contains two coupons which entitle your vehicle to free inspections after 2500 km (1500 miles) and 10 000 km (6000 miles) running respectively. If possible, let the dealer who supplied the vehicle carry out these inspections. In exceptional cases, however, you can have them done by any other authorised Volvo workshop. **Our six-month guarantee only remains valid providing that the two above-mentioned free inspections are carried out at about the correct mileage and that the vehicle is serviced in accordance with the instructions given in this book.**

In order to ensure proper service for your vehicle in the future, it is advisable to make arrangements with your Volvo workshop concerning subsequent regular service inspections.

Contents

TYPE PLATES	6
-------------------	---

OPERATING

Instruments and controls	8
Cab	24
Starting and running	26
Running-in	26
Action before starting	27
Starting the engine	27
Changing gear	29
Stopping the engine	32
Towing	32
Inflating the tyres	34
General advice	35

MAINTENANCE

General	37
Maintenance schedule	38
Engine, general	40
lubricating system	43
fuel system	47
cooling system	55
turbo-compressor	61
Electrical system	64
Power transmission, clutch	70
gearbox	72
rear axle	79
Brake system	84
Front end and steering gear	90
Power steering	90
Frame	95
Suspension system	95
Wheels	96
Body	101
Precautions to be taken during cold weather	102

SPECIFICATIONS

General data	105
Engine	108
Electrical system	110
Clutch	110
Gearbox	111
Rear axle	112
Brakes	112
Front end and steering gear	113

LUBRICATING CHART

WIRING DIAGRAM

TYPE PLATES

1. Gross vehicle weight plate.

Fixed on inside of left-hand door.

2. Chassis number plate.

Fixed on inside of left-hand door.

3. The type and chassis number are also stamped on the right-hand frame member, behind the front spring anchorage. (On early production trucks at extreme front end of frame member.)

4. The engine type designation, part number and serial number are stamped on the left-hand side of the engine above and to the left of the injection pump.

Late prod. trucks have these numbers on the right-hand side of the engine at the top, front.

5. Gearbox plate.

Fixed on right-hand side of gearbox.

6. Rear axle plate

Fixed on right-hand side of rear axle casing.

In all contacts with your dealer concerning your truck and when ordering replacement parts, state the chassis type designation and serial number. This facilitates the handling of your inquiries or orders and means that time is saved for you as well. Concerning the engine, gearbox or rear axle, the designations and numbers of these parts should also be stated.

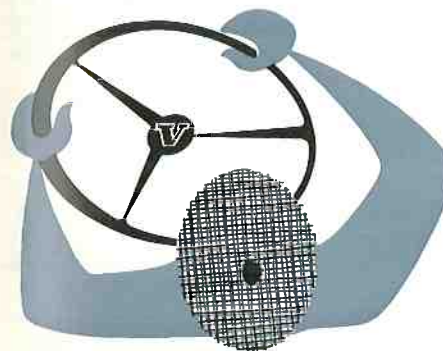
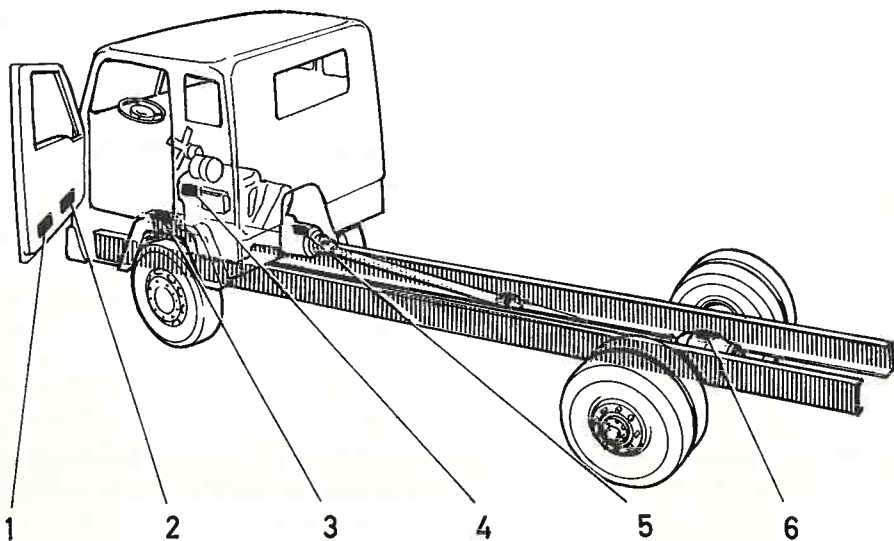

OPERATING

Before starting to run your truck, make yourself acquainted with the various instruments and controls. After starting, and now and again while driving, always make a habit of checking that the instruments give normal readings.

INSTRUMENTS AND CONTROLS

	Description on page:	
1	Starting button	15
2	Switch, spotlight (Note. Merely ready for use, spotlight not fitted)	13
3	Switch, foglight (Note. Merely ready for use, foglight not fitted)	13
4	Switch, all-round warning lamps	14
5	Stop control	15
6	Hand throttle control	15
7	Windscreen wiper control	14
8	Switch, differential lock, (wheels)	20
9	Switch, differential lock between axles (Note. Only on 6x4 vehicles)	21
10	Switch, power take-off I (extra equipment)	21
11	Switch, power take-off II (extra equipment)	21
12	Electric power outlet	13
13	Exhaust brake switch	11
14	Switch, direction indicators	13
15	Hand control, trailer brakes	11
16	Hand control, parking brakes	10
17	Gear lever	19
18	Operating control, overdrive (SR61, 16-speed)	20
19	Defroster control	22
20	Air flow control "floor", right-hand heater	22
21	Temperature control, right-hand heater	22
22	Warning lamp, direction indicators, trailer	13
23	Warning lamp, direction indicators, tractor unit	13
24	Warning lamp, oil pressure	16
25	Oil pressure gauge	16
26	Temperature gauge	17
27	Warning lamp, compressed air—running brakes (concerns both circuits)	10
28	Tachometer	18
29	Warning lamp, parking brakes	10
30	Switch, windscreen washer	14
31	Switch, fan, right-hand heater	22
32	Switch, headlights and instrument lighting	12
33	Warning lamp, full headlights	12
34	Warning lamp, charging	12
35	Compressed air gauge	10
36	Fuel gauge	17
37	Main switch	15
38	Tachograph or speedometer	18
39	Warning lamp, cooling system (high coolant temperature or low coolant level)	16
40	Switch, fan, left-hand heater	23
41	Temperature control, left-hand heater (located to right of driving seat, cannot be seen in illustration)	23

Variations can occur between different markets.

The figures after the headings on the following pages refer to the numbers in the first column above.

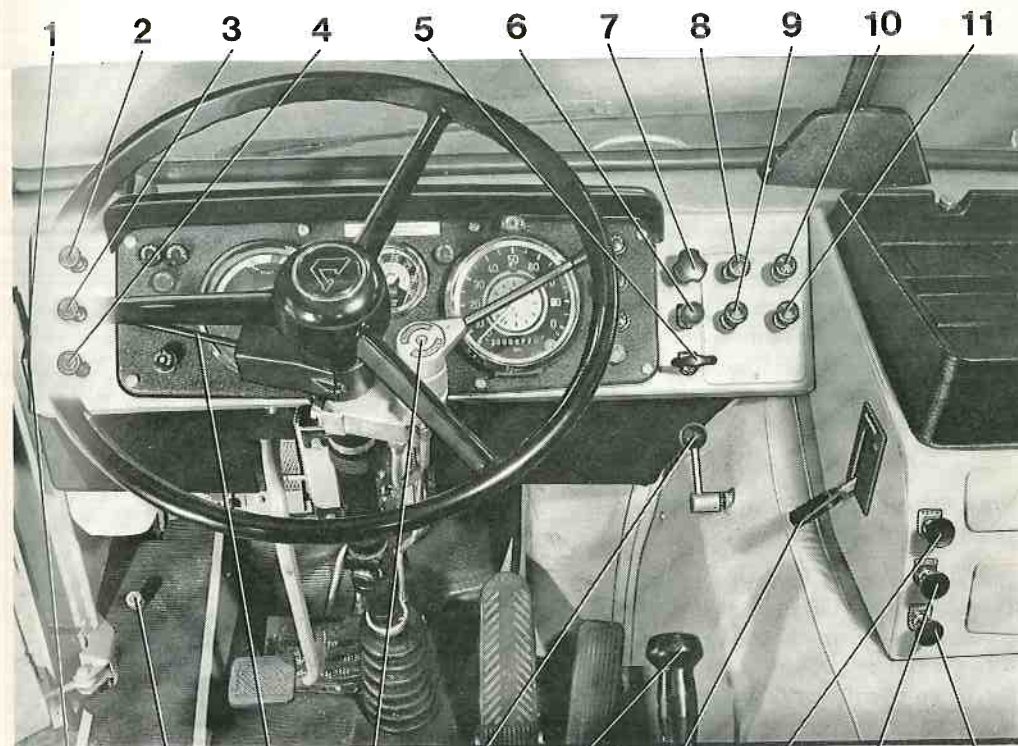

12 13 14 15 16 17 18 19 20 21

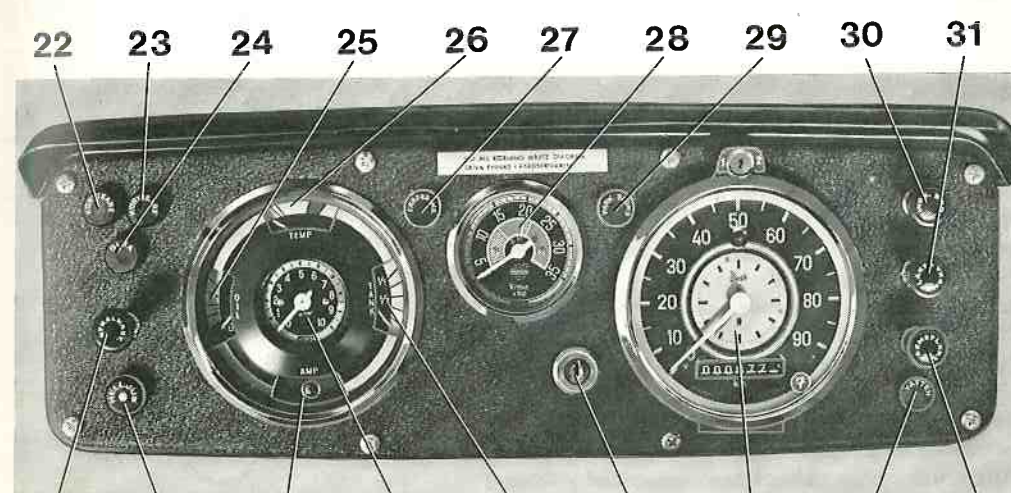

32 33 34 35 36 37 38 39 40

COMPRESSED AIR GAUGE (35)

The compressed air gauge shows the pressure available in the compressed air tanks for the front wheel and driving wheel circuits. The gauge has two pointers. The white pointer indicates the front wheel circuit pressure and the red pointer indicates driving wheel circuit pressure.

The green field on the compressed air gauge indicates the working pressure of the compressed air system.

Do not start driving the truck while the compressed air warning lamp is on.

**WARNING LAMP, COMPRESSED AIR (SERVICE BRAKES) (27)**

This warning lamp is connected to both brake circuits. The lamp lights up and remains on when the air pressure in one of the brake systems is less than 3.9–4.5 kp/cm² (55–64 lb./sq.in.).

Never start driving the truck while the warning lamp is on.

If the warning lamp should light up while the truck is being driven, stop it immediately and investigate the reason.

**WARNING LAMP, PARKING BRAKES (29)
HAND CONTROL, PARKING BRAKES (16)**

When the hand control is in its forward position and the compressed air system is charged, the parking brakes are disengaged.

When the control is moved rearwards, the parking brakes are applied gradually. When the control is in its rear position, the parking brakes are fully applied. The warning lamp goes on when the control is moved rearwards and remains on as long as the brakes are applied.

The truck may not be driven while the warning lamp is on.

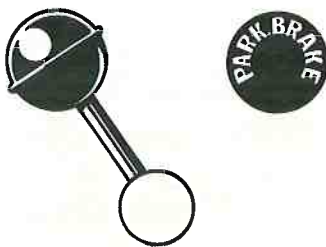
**HAND CONTROL FOR TRAILER BRAKES (15)**

The trailer can be braked separately without the brake system on the tractor unit being influenced, this being done by using a hand control under the steering wheel. When the brake pedal is pressed, this influences the brakes on both the tractor unit and the trailer.

The manual control should be in its fully forward position when the truck is driven. When the hand control is moved rearwards, the trailer brakes are applied gradually. This control can be used to avoid the jack-knifing effect.

Do not forget to move back the control after applying the brakes.

Do not use this control as a parking brake.

**EXHAUST BRAKE SWITCH (13)**

The exhaust brake is used when needed on downgrades in order to decrease wear on the ordinary brake system. It can also be used to supplement the footbrake when reducing speed. The exhaust brake is effective at high engine speed (1500 r.p.m. upwards). (Engine speed must not, however, exceed 2200 r.p.m.) The exhaust brake remains in function as long as the switch is held pressed. This switch must not be used to stop the engine. There is a separate stop control, **Use the exhaust brake every day to avoid sticking due to carbon deposits.**

WARNING LAMP, CHARGING (34)

This lamp is red and remains on while the batteries are discharging. If the lamp should light up while the truck is being driven there is either something wrong with the electrical system or the alternator drive belt is insufficiently tensioned and is slipping on the alternator pulley, this resulting in poor charging. The charging control lamp can also light up while the truck is being driven due to the fact that the over-voltage protector has cut out because of an over-voltage surge.

The engine must be stopped and the main switch turned off to reset the over-voltage protector.

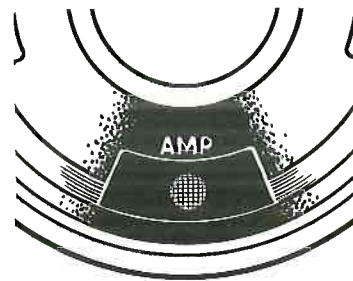
**SWITCH FOR HEADLIGHTS AND INSTRUMENT LIGHTING (32)**

When this switch is pulled out one notch, the parking lights light up front and rear and the instrument lighting also goes on. When the switch is pulled out all the way, the headlights are also switched on.

The instrument lighting is regulated by turning the switch: clockwise — stronger lighting, anti-clockwise — weaker lighting.

Change-over from full headlight to dipped headlight and vice-versa is carried out by using the direction indicator lever.

**WARNING LAMP, FULL HEADLIGHTS (33)**

This warning lamp lights when the full headlights are on.

**DIRECTION INDICATOR SWITCH, LIGHTING SWITCH AND FULL HEADLIGHT FLASHER (14)**

All the above mentioned functions are controlled by means of the lever to the left of the steering wheel. When this lever is moved forward, the right-hand direction indicator switches on, and when it is moved rearwards the left-hand direction indicator is switched on. Change-over from full headlights to dipped headlights and vice-versa is carried out by pulling the lever upwards towards the steering wheel. The lever is also used to flash the headlights when the headlights are not switched on. The full headlight flasher is operated by moving the lever upwards towards the steering wheel and the full headlights remain on until the lever is released again.

**WARNING LAMP, DIRECTION INDICATORS, TRACTOR UNIT (22)****WARNING LAMP, DIRECTION INDICATORS, TRAILER (23)**

These warning lamps flash in unison with the direction indicator flashers.

**ELECTRIC POWER OUTLET (12)**

To facilitate the use of an inspection lamp or other equipment, the truck is fitted with an electric power outlet.

SWITCHES FOR FOGLIGHT AND SPOTLIGHT (3, 2)

F and G-88 trucks are ready fitted out for the installation of foglights and spotlights. This means that switches, relays and cables are already installed. Only slight supplementary work is needed in connection with the installation of extra lighting units.



SWITCH FOR ALL-ROUND HAZARD WARNING LAMPS (4)

When this switch is pulled out, all the direction indicator flashers on the truck start operating. A warning lamp in the switch flashes in unison.

The all-round warning lamps are not connected over the main switch. This means that they function no matter whether the main switch is on or not. The all-round flashers are only to be used when you are forced to park the truck where it can be a danger for other road users.

Note that the legal regulations for the use of flashing warning lights can vary in different countries.

**CONTROL FOR WINDSCREEN WIPERS (7)**

The windscreen wipers are compressed air driven and are started by turning the control in a clockwise direction. The speed of the windscreen wipers is infinitely variable.

The windscreen wipers stop if the control is turned in an anti-clockwise direction. If it is given an extra turn, the windscreen wipers go into their parking position. Never allow the windscreen wipers to operate on a dry and dusty surface since the glass and wiper blades can easily become damaged.

**SWITCH FOR WINDSCREEN WASHERS (30)**

The windscreen washers operate when this switch is pulled out.

The windscreen washers container has a capacity of about 1.5 litres (1.3 quarts) and is located in the cab to the left under the dashboard.

**STOP CONTROL (5)**

When the engine is to be stopped, this control is pulled out. This influences the fuel injection pump so that it no longer pumps fuel into the cylinders.

Allow the control to remain out while the vehicle is standing parked. Do not forget to turn off the main switch as well.

**MAIN SWITCH (37)**

Before starting the engine, turn the key in the main switch clockwise. The key must remain in this position while the truck is being driven. The main switch is used to turn on the electrical equipment.

**HAND THROTTLE CONTROL (6)**

Apart from the accelerator pedal there is also a hand throttle control. This is used to give the engine the desired speed when starting and idling and also when operating auxiliary equipment.

**STARTING BUTTON (1)**

When the starting button is pressed in, the starter motor is cut in. Release the button as soon as the engine has started.



WARNING LAMP, OIL PRESSURE (24)

The warning lamp lights up when the oil pressure decreases below 0.5 kp/cm^2 (7 lb./sq.in.). If this lamp should go on while the truck is being driven, stop the engine and find out why.

**OIL PRESSURE GAUGE (25)**

In order to check the oil pressure, there is also an oil pressure gauge in addition to the warning lamp.

The oil pressure gauge shows the pressure of the oil in the engine lubricating system. The oil pressure is dependent on engine speed and temperature and also on the viscosity of the oil used. **Normally the oil pressure should be $3-5 \text{ kp/cm}^2$ ($43-71 \text{ lb./sq.in.}$) when running with the engine warm.** If the pressure goes down below 0.5 kp/cm^2 (7 lb./sq.in.), the warning lamp lights up.

NOTE. If the oil pressure should fall below 0.5 kp/cm^2 (7 lb./sq.in.) when idling with the engine warm, this is quite normal as long as the pressure at operating speed is not less than 3 kp/cm^2 (43 lb./sq.in.).

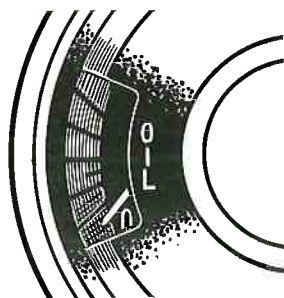
**WARNING LAMP, HIGH COOLANT TEMPERATURE AND LOW COOLANT LEVEL (39)**

If the lamp should light up while the truck is being driven, allow the engine to run at idling speed for about a minute or so before stopping it. Check whether the temperature gauge is showing an excessively high reading. If this is the case, it depends on the fact that either the coolant level is too low (check this through the radiator filler cap) or the coolant temperature is



too high for some particular reason. If the coolant level is too low, check the cooling system for leakage before adding new coolant.

If the coolant temperature is too high for some reason, have the vehicle cooling system checked in the workshop.

On the late prod. model, the relay in the warning lamp circuit has a built-in function control. When the starter key is turned, the lamp goes on and lights for 1 second. This shows whether the lamp is functioning or not.

TEMPERATURE GAUGE (26)

The temperature gauge shows the temperature in the engine cooling system and thereby the working temperature of the engine which should be between 70 and 85°C (158 and 185°F). The temperature gauge pointer should remain within the green field during normal driving.

During very hot driving conditions, it is permissible for the pointer to go into the shaded red field.

The pointer must not go into the plain red field.

If the coolant temperature should exceed about 98°C (208°F) the warning lamp lights up.

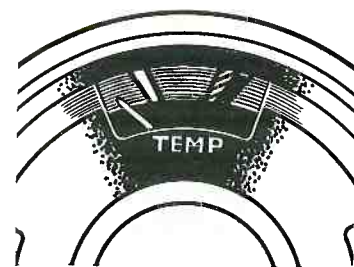
**FUEL GAUGE (36)**

The fuel gauge is divided up into six different sections, the two furthest down being in another colour. The fuel tank has no reserve and the tank is empty when the indicator is at 0.

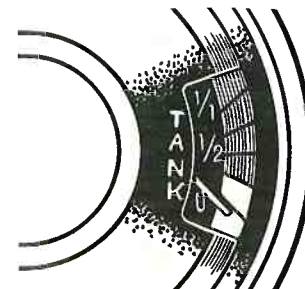

TACHOMETER (28)

The tachometer registers the engine speed and is graduated in hundreds of revolutions per minute.

- 1 Low speed range.
- 2 Operating speed range. **The engine speed should be kept within this range as far as possible when driving (1300–2000 r.p.m.).**
The highest recommended speed for continuous loading (for example, on long-distance runs on motorways) is 2000 r.p.m.
- 3 High-output range. This speed range is permissible for short periods when accelerating, changing gear, etc.
- 4 This speed range is marked in red and must not be used.

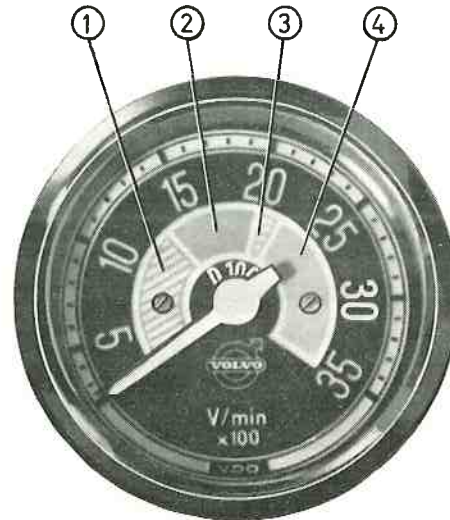

Tachometer

TACHOGRAPH (OR SPEEDOMETER) (38)

The tachograph is of the 7-day type, which permits registration for 7 days without having to change the registration discs.

The speed, total distance covered and time can be read off from the driving seat. There is also a running control which shows that the instrument is functioning, and a warning lamp which lights when the speed exceeds 70 km.p.h. (42 m.p.h.). The speed, distance covered, running and rest times for each day are recorded on the registration discs fitted at the back of the instrument.

Switching over on change of drivers is done with either of the keys supplied which are marked 1 and 2 respectively.

The registration discs should preferably be changed and the clockwork wound up once a week as follows:

- 1 Open the instrument with the key.
- 2 Remove the retainer (bayonet fitting) and take out the registration discs.

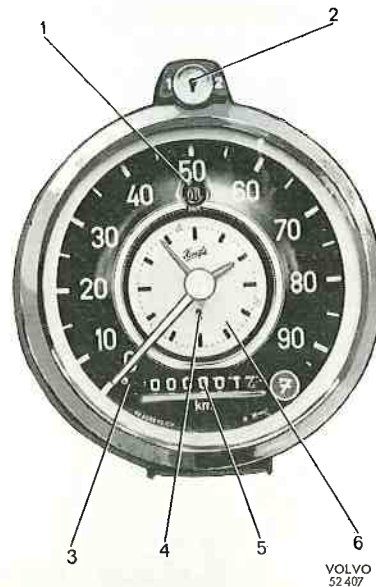

- Tachograph
1. Warning lamp
 2. Lock and change of drivers
 3. Speedometer
 4. Running control
 5. Mileometer
 6. Clock

VOLVO
52.407

- 3 Wind up the clockwork by pulling out the lever on the side of the clock and moving it backwards and forwards until resistance is felt from the winding ratchet. The instrument is also fitted with an adjustment indicator.
- 4 Fit a batch of new registration discs after having filled in the necessary information. Check that the edges of the discs are not creased and that the discs are attached to each other with narrow strips, which is essential for 7-day registration.
- 5 Turn the discs so that the right time comes in line with the red mark on the registration plate and fit on the retainer.
- 6 Close the instrument and remove the key.

N.B. The instrument must not be opened while driving. If the instrument is opened for any other purpose than replacement of the discs, the used (loose) discs must be removed before the instrument is closed again. The instrument must not be started without discs, as this can damage the sapphire stylus.



GEAR LEVER WITH TOGGLE SWITCH (17)

The gear lever has four positions for driving forward and one for driving in reverse. The gear lever is fitted with a toggle switch for change-over between the low-speed and the high-speed ranges. See pages 29 and 30 for the gear-changing procedure.

GEAR-CHANGING CONTROL FOR SR 61 (16-speed) (18)

Change-over between the overdrive position and the direct drive position (in the overdrive section) is carried out by using the selector control and the clutch pedal. See page 31 for the gear-changing procedure.



DIFFERENTIAL LOCK

Switch for differential lock (8)

The differential lock is engaged by pulling out the switch. The switch has a built-in warning lamp which lights up when the switch is pulled out.

Engaging the differential lock

The differential lock may only be used on slippery surfaces. If possible engage the differential lock just before reaching the slippery surface. Engaging may be carried out while the truck is running independent of speed and also under loading.

NOTE. If you reach a curve with a firm surface, disengage the differential lock.

This is particularly important when the truck is loaded. Neglect in this respect can result in a broken driving axle. Disengage the differential lock before the curve since it cannot be disengaged while the truck is cornering.

The differential lock must not be engaged while one of the driving wheels is spinning.

Engagement in such cases is carried out as follows: Press down the clutch pedal, engage the differential lock and then engage the engine again carefully by slipping the clutch (a suitable gear being engaged). If the differential lock is engaged with one of the wheels spinning, this will inevitably lead to damage on the dog clutch in the differential lock.

The differential lock should not be engaged when the truck is being driven with snow chains on the wheels. We should like to warn you particularly against the practice of using a chain on only one driving wheel when passing over slippery surfaces.

Switch, differential lock, 6 × 4 vehicles (8, 9)

6 × 4 vehicles are fitted with three differential locks, one in each rear axle and one in the transfer box between the axles.

The differential locks are operated by means of two switches, one joint switch for both rear axles (DIFF., WHEELS) and one for the transfer box (DIFF., AXLES). When driving on a slippery surface, the differential lock in the transfer box should primarily be used. If the truck should start slipping in spite of this, the differential locks in the rear axles should also be engaged. When driving with all three differential locks engaged, care should be taken since the bogie has a tendency to drive the vehicle straight forwards.



SWITCHES, POWER TAKE-OFFS (10, 11)

The switches have built-in warning lamps. In the case of the R 60 and the SR 61 there are three types of power take-off — a side-mounted and two rear-mounted.

The power take-offs are engaged in the following way: Press down the clutch pedal, wait for 5 seconds and then engage the power take-off. Then release the clutch pedal again.

The power take-off should not be engaged while the truck is being driven.

If it must be engaged while the truck is being driven for some reason, no gear-changing is to be carried out since the synchronization is then subject to very rapid wear because of the extra loading.

HEATING AND VENTILATION CONTROLS

The F 88/G 88 trucks are fitted with two heaters, one located to the right in front of the passenger seat and one to the left below the driving seat. The right-hand heater feeds warm air to the defroster and passenger seat and the left-hand heater to the driving seat.

The left-hand heater takes air from inside the cab while the right-hand heater takes in fresh air.

The right-hand heater utilizes slipstream. At speeds above 50 km/hour (30 m.p.h.) it is only necessary to use the fan on this heater under extreme conditions. The pivoted side nozzles are normally used to defrost the side windows. In warm weather they can also be used to provide "air-conditioning" by turning them to face the driver and passenger.

Right-hand heater

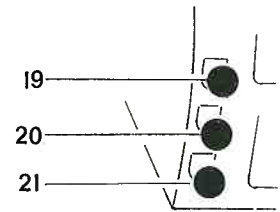
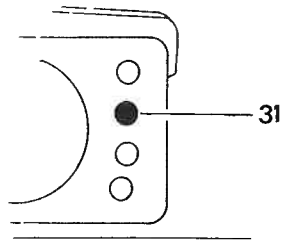

The best defroster effect is obtained with the controls in the following position: Floor control (20) fully pushed in.

The defroster and temperature controls (19, 21) pulled out all the way.

The switch (upper) for the right-hand heater fan (31) pulled out one notch.

Maximum temperature is obtained with the following settings:

Floor, defroster and temperature controls fully pulled out. The switch (upper) for the right-hand heater fan pulled out one notch.

Left-hand heater

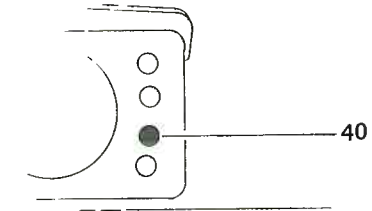
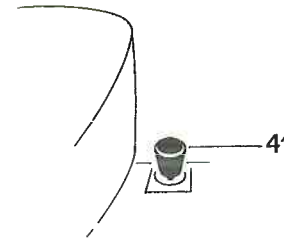

Maximum temperature from the left-hand heater is obtained through the following settings of the controls:

Temperature control (41) fully pulled out.

Switch (lower) for left-hand heater fan (40) pulled out one notch.

Seats

Adjustment of fore-and-aft and vertical positions

The seat can be adjusted fore-and-aft by releasing the catch (1) whereby the vertical position automatically changes. Press your feet against the floor and move the seat to its most comfortable position.



VOLVO 52 442

Adjusting the seat suspension

The suspension can be adjusted to suit the weight of the driver. Move the catch on the lever (2) to increase or decrease spring tension. Move the lever upwards or downwards until the seat suspension suits the weights of the driver.

The seat suspension is correctly adjusted when the spring indicator (3) is in line with the sideplate when the driver is sitting on the seat.

Adjusting backrest inclination

Backrest inclination is adjusted by pressing in either of the two levers (4) on the inside of the backrest sideplate.

Cab

TIPPING UP THE CAB

- 1 Move the gear lever to neutral
- 2 If there is room let the doors remain fully open in order to facilitate tipping the cab. If there is not sufficient room for this, make sure that the doors are properly closed.
- 3 Pull the safety catch handle backwards and pull up the locking handles.
- 4 Lift the rear edge of the cab as far as it will go and so that the locking arm engages.

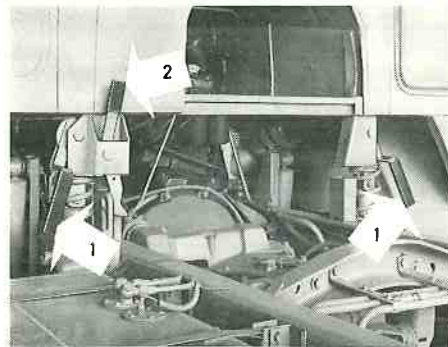

1. Locking handle
2. Safety catch handle

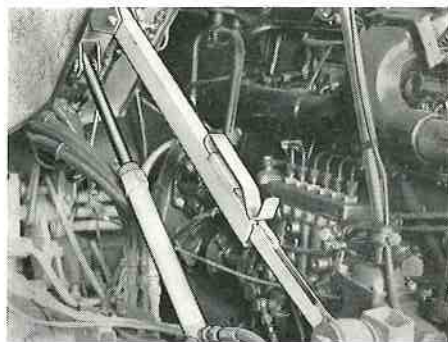

Locking arm engaged in tipped position

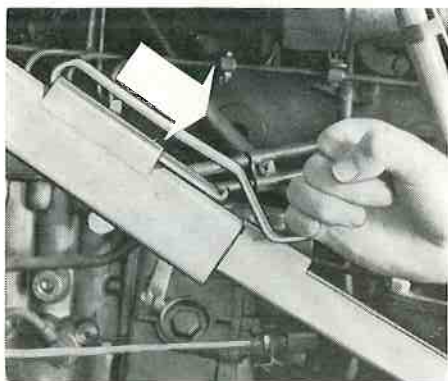

Catch handle

TIPPING BACK THE CAB

- 1 Pull the catch handle backwards and downwards so that it comes into the position as shown in the figure.
- 2 Take the weight of the cab and then lower it. Make sure that the locking handles are in the upper position.

On trucks with hydraulic cab tilting:

Open the valve on the hydraulic pump so that the cab goes down.

- 3 Secure the cab by turning down the locking handles. The safety catch is spring-loaded and operates automatically.

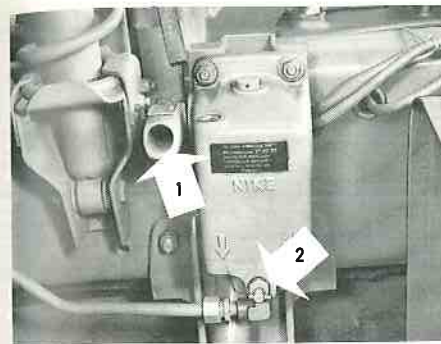

Hydraulic pump
1 Attachment for pump handle
2 Valve

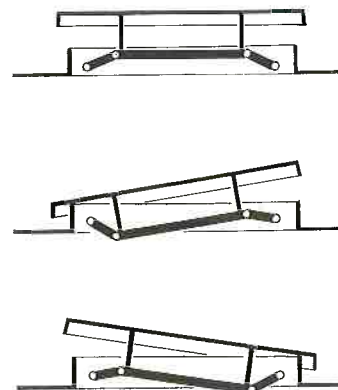

ROOF HATCH

Roof hatch

To open the roof hatch, press one or both of the handles upwards. The hatch can be set in different positions as shown by the sketch.

STARTING AND RUNNING

Running-in

When the vehicle is new it should be treated with care, particularly during the first 5000 km (3000 miles). Do not utilise full engine output for more than short stretches.

Avoid high engine speeds. Instead allow the engine to operate at speeds which are 400–500 r.p.m. below the permissible maximum.

Do not drive fast with a full load and avoid "labouring". Keep an eye on the temperature and oil pressure.

Use the brakes carefully during the first part of the running-in period. This will provide good contact between the drums and the brake linings.

LUBRICATION DURING THE RUNNING-IN PERIOD

During the running-in period the moving parts of the vehicle must be allowed to bed down in order to obtain smooth and wear-resistant contact surfaces. For this reason oil changing should be done more frequently during the running-in period than is normal later on.

The **engine** oil must be changed for the first time after 1000 km (600 miles) running. The engine oil is then changed for the second time in conjunction with the first cost-free guarantee inspection after 2500 km (1500 miles) running. Subsequent oil changes must then take place at the intervals shown in the maintenance schedule.

During the running-in period the **engine oil filter** must be changed after the first 5000 km (3000 miles). Subsequent changes should be done after every 10 000 km (6000 miles).

The oil and oil filter in the **gearbox** and the oil in the **rear axle** must be changed after the first 5000 km (3000 miles), when the gearbox and rear axle must be flushed.

The **power steering** fluid must also be changed after the first 10 000 km (6000 miles).

All Volvo engines are test-run before delivery both on the test-bench and in the vehicle on the test-track. This assures that all clearances and fits are satisfactory and we can therefore accept no responsibility for any damage due to careless driving.

Action before starting

1 Checking the coolant level

The coolant level should be up to the metal marker in the radiator filter opening.

Top up if necessary with:

water + glycol in winter

water + anti-rust agent in summertime.

For further details, see under "Maintenance" on page 57.

2 Checking the oil level in the engine crankcase

The oil level should lie between the marks on the dipstick.

If the oil level lies below the lower mark, top up with oil of the same quality already in the engine.

3 If the engine has not been used for some length of time, or if adjustments have been made to the fuel system, the fuel system should be air-vented.

4 Check the lighting, brake lights, direction indicators and horn. Wipe off the lamps and reflectors.

Starting the engine

1 Check that the parking brake is applied.

2 Check that the gear lever is in neutral.

3 Push in the stop control.

4 Switch on the main switch.

5 Press in the starting button and keep the accelerator pedal **fully depressed** until the engine starts. (For cold weather procedure, see next page.)

Do not race the engine.

6 Check that the warning lamps of the compressed air system go out when the pressure in the brake circuits reaches 3.9–4.5 kp/cm² (55–64 lb./sq.in.) and that normal operating pressure is obtained in the brake system, see page 87.

Test the brakes before driving off.

Starting the engine during cold weather

In order to facilitate starting during cold weather there is a special cold-starting device on the injection pump. Proceed as follows in order to make sure that the cold-starting device functions correctly:

- A Press down the accelerator pedal as far as it goes (in order to facilitate point B).
- B Pull out the hand throttle control as far as it will go.
- C Engage the cold-starting device by pulling out the cable control and then releasing it. N.B. Due to the viscosity of the oil there may be a slight delay before the cold-starting device engages.

In very cold weather, subsequent engagement of the cold-starting device can be facilitated by operating it after finishing driving. Since the stop control cannot then be pulled out, the vehicle must be parked with the gear lever in neutral position. It is also necessary to take action to ensure that the vehicle cannot start moving on its own.

- D Fully depress the accelerator pedal again.
- E Push in the hand throttle control (in order to avoid excessive engine speed when starting).
- F Start the engine.

Do not "race" the engine.

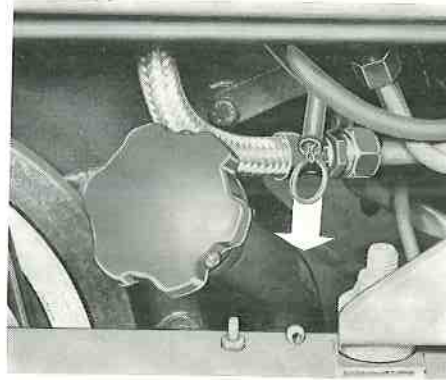

Cold-starting control

Running warm

Never "race" a cold engine. When the lubricating oil is cold it is so thick that it cannot penetrate into all the lubricating points of the engine, so that there is a risk of seizing. This particularly applies to the turbo-compressor.

Do not run the engine warm by allowing it to idle, but begin driving with light engine loading when normal oil pressure has been obtained and the compressed air system charged up so that the parking brake can be released. The vehicle should be driven in a lower gear than normal and with an engine speed which is 400–500 r.p.m. lower than the maximum permissible.

Avoid "labouring" and high engine speed.

Never load the engine fully before it has reached normal operating temperature.

Changing gear**TYPE R 60 GEARBOX**

The R 60 is an 8-speed fully synchronized gearbox. It consists of a 4-speed front section which is controlled with the gear lever and a 2-speed, compressed air operated rear section, by means of which the high and low speed ranges are engaged.

The gear positions 1 to 4 represent the low speed range and the positions 5 to 8 represent the high speed range.

Changing between the low and high speed ranges is done by means of the selector switch on the gear lever.

When starting and driving at speeds of up to about 20 km.p.h. (12 m.p.h.), the 4 speeds are used with the selector switch on **LOW**.

When driving at speeds above 20 km.p.h. (12 m.p.h.), the 4 speeds are used with the selector switch on **HIGH**.

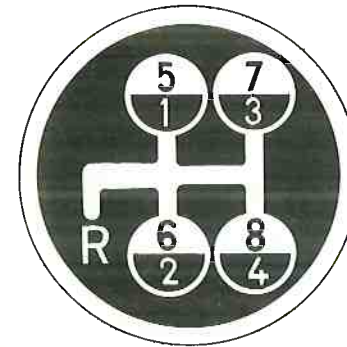

Gear positions



Selector switch

Since the HIGH speed range is used for more than 90% of the driving time, the gearbox is just as easy to operate as an ordinary 4-speed gearbox.

Start the vehicle in a sufficiently low gear to enable starting to be done without jerking or having to slip the clutch. (For example a loaded truck in 1st, an empty vehicle in 3rd or 4th.)

Always try to let the engine operate within its effective working range, i.e. 1300–2000 r.p.m.

Watch the tachometer.

When changing to a higher speed, the gear lever should be held in the neutral position for an instant before engaging the new speed. When changing to a lower speed it is advisable not to ease back the accelerator pedal providing that the gear lever is moved fairly quickly. The engine is then able to increase speed to correspond to the higher ratio.

Never change down at too high a speed, for example, when the engine acts as a brake when running downhill. This can cause damage due to overspeeding of the engine and power transmission. Use the tachometer as a guide when changing down.

Changing up is done as follows:

- A Changing from 1st up to 4th speed is done in the same way as on an ordinary 4-speed gearbox.
- B Move the selector control from LOW to HIGH with the gear lever in 4th speed.
- C Engage 5th speed by moving the gear lever to the 1st speed position. The high ratio is engaged automatically when the gear lever passes through the neutral position.

The gear lever is locked in the neutral position during the time that changing from LOW to HIGH takes place.

- D Changing from 5th up to 8th speed is done in the same way as on a ordinary 4-speed gearbox. This means that 5th speed has the same position as 1st, 6th speed the same as 2nd, 7th speed the same as 3rd and 8th speed the same as 4th.

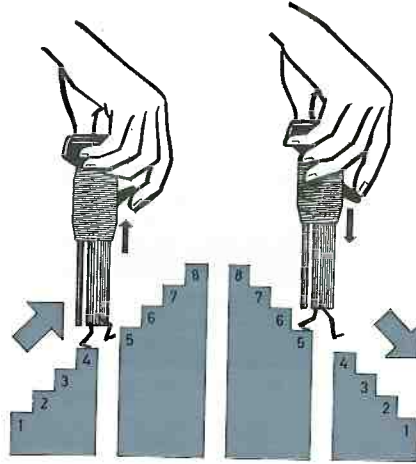

VOLVO
52417

Changing down is done in a corresponding manner. Pre-select by moving the selector control from HIGH to LOW with the gear lever in 5th speed position. (When doing this the vehicle speed must not exceed about 20 km.p.h. = 12 m.p.h.)

Pre-selection is not to be carried out until immediately before gear-changing.

At low temperatures the oil in the gearbox is viscous and it may therefore take a little longer to change from the HIGH to the LOW range than when the oil is warm.

N.B. Reversing should only be done with the selector control at **LOW**. The reverse gear is not synchronized and **on no account must changing from HIGH to LOW be done while reversing.**

N.B. If the air pressure is too low, it may happen that the auxiliary gearbox remains in the disengaged position and the gear lever will lock in the neutral position. When the air pressure rises, the auxiliary gearbox normally engages and the gear lever can be moved to the required position. If the gear lever still locks in the neutral position in spite of the fact that the air pressure has increased to above 4 kp/cm² (57 lb./sq.in.), the selector control on the gear lever can be moved to the opposite position and back again, after which it will be possible to move the gear lever to the desired position.

TYPE SR 61 GEARBOX

The type SR 61 gearbox consists in principle of an R 60 gearbox (8-speed) fitted with a supplementary overdrive which provides two ratios on each of the eight gears in the main gearbox. This provides a total of 16 ratios.

Gear-changing between the overdrive position and the direct drive position (in the supplementary gearbox) is carried out pneumatically by means of a pre-selector (toggle switch) and by using the clutch pedal. The pre-selector control is located to the right of the driver on the dashboard. Beside the control there is a green warning lamp which lights up when the overdrive position is engaged.

Changing gear from the overdrive position to the direct drive position is carried out as follows:

- 1 Move down the pre-selector control (the lamp remains lit until gear-changing has been completed).
- 2 Wait for a suitable engine speed, press down the clutch pedal as far as it will go and then release it again — direct gear is engaged.

(Since gear-changing is carried out very quickly, it is normally not necessary to wait before releasing the clutch pedal).

Note. Gear-changing in the overdrive occurs during the period the engine is disengaged. In the case of incomplete clutch disengagement, gear-changing can be delayed so that the neutral position is obtained.

Remedy: Press down the clutch pedal all the way so that overdrive engages. (If necessary check the gear-changing point for the overdrive, see page 77).

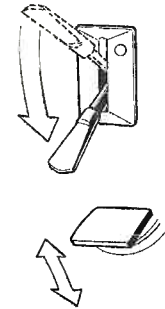

Changing gear from the direct gear position to the overdrive position is carried out in a corresponding way.

(The lamp does not light up until gear-changing has been completed.)

Changing gear from the overdrive position to the direct drive position and vice-versa at the same time as gear-changing is carried out in the main gearbox.

- 1 Move the pre-selector control down (or up).
- 2 Wait for a suitable engine speed and then carry out gear-changing as usual with gear lever — the operation is then complete.

For example, if you are driving in 8th direct gear and would like to change down to 7th overdrive. Move up the pre-selector control. Wait for a suitable engine speed and then change gear as usual between 8th and 7th.

Concerning gear-changing with the gear lever, see under the heading "Type R 60 gearbox".

Stopping the engine

If the vehicle has been subjected to hard running, the engine should be allowed to idle for about a minute before it is stopped in order to reduce heat stresses in the engine and to avoid loss of coolant which can occur when the water circulation in the engine is suddenly shut off. To stop the engine, pull out the stop control on the instrument panel. This affects the injection pump in such a way that it no longer pumps fuel into the cylinders.

Let the stop control remain in the pulled-out position until starting the next time. Do not forget to switch off the key switch.

Towing

NOTE. Remove the rear propeller shaft section if the truck is to be towed. Otherwise the gearbox can seize through insufficient lubrication. When moving the truck a short distance (for example about 100 m) the propeller shaft does not need to be removed.

NOTE. High gear must be engaged in the gearbox.

If the gear lever toggle switch is not in HIGH (H) to start with, compressed air must be fed to the parking brake tank for change-over to HIGH. If HIGH gear cannot be engaged, the propeller shaft section must be removed even when moving the truck a short distance.

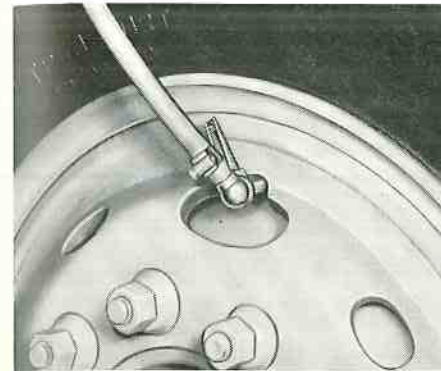
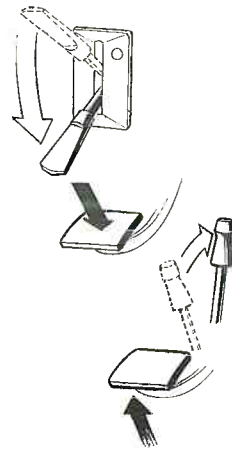

Wheel connection

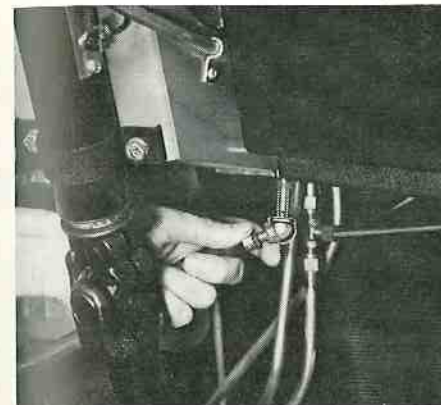

Tank valve connection

When the vehicle is to be moved or towed and the engine cannot be started so that the compressor is unable to charge up the compressed air system, the brake cylinders of the driving wheels must be connected to a compressed air supply in order to release the parking brake.

If an outside compressed air supply is available, the compressed air system can be filled with air through the drain cock on the "wet" air tank (outer, lower). If no outside compressed air supply is available, the parking brake can be released as follows:

- 1 Block the wheels so that the vehicle cannot roll.
- 2 Move the hand control for the parking brake to the front position.
- 3 Connect the clamping head of the tyre inflating hose to the tyre valve, see figure.
- 4 Connect the other end of the hose to the tank valve which is placed under the instrument panel, see figure.

This fills the lines to the lower side of the driving wheel cylinders and the parking brake will release providing that the pressure in the tyre exceeds about 5 kp/cm^2 (71 lb./sq.in.) (complete release at $5.8\text{--}6.6 \text{ kp/cm}^2 = 82.5\text{--}94 \text{ lb./sq.in.}$).

The compressed air gauge in the vehicle does not give a reading, but filling can be terminated as soon as the air flow has ceased.

N.B. The parking brake should be released in the order mentioned above since the driver should be sitting in the vehicle in case it begins to roll.

The vehicle can then be towed, but note that this must be done with a rigid drawbar or similar since there will be no braking effect available from the foot brake. Emergency braking can, of course, be carried out by moving the hand control for the parking brake to the rear position, but after this the system must be filled again in order to release the parking brake.

Inflating the tyres

If necessary, the tyres can be inflated by using the compressed air system of the vehicle as follows:

NOTE. It is not necessary to release the parking brake.

- 1 Connect the clamping head of the tyre inflating hose to the tank valve under the instrument panel.
- 2 Connect the other end of the tyre inflating hose to the tyre which is to be pumped up.
- 3 If necessary start the engine so that the compressor can charge up the compressed air system.

The maximum pressure which can be obtained in the tyres is the same as the maximum working pressure in the system, i.e. 7.9–8.5 kp/cm² (112–121 lb/sq.in.).

GENERAL ADVICE

- 1 Check after starting and now and again while driving that the instruments give normal readings. If any warning lamp should light while driving, stop and find out the reason.
- 2 Never "race" a cold engine. Do not run the engine warm by idling, but begin driving with light engine loading.
- 3 Watch the tachometer. Let the engine operate within its effective working range, i.e. 1300–2000 r.p.m. Maximum engine speed under continuous loading is 2000 r.p.m.
Never "race" the engine, which should particularly be remembered when using the engine as a brake when running downhill.
- 4 Never screen off the radiator. The thermostats always maintain the engine at the correct temperature. Check the coolant level regularly and use the correct coolant. Also check the hoses and belt tension. Do not drive with a leaking cooling and heating system.
- 5 Never start driving before the warning lamps for the brake system have stopped flashing. Do not forget the parking brake.
- 6 Do not rest your foot on the clutch pedal. Do not slip the clutch unnecessarily. The gearbox always makes it possible to use the correct drive ratio.
- 7 Do not change gear when running with power take-off engaged.
- 8 Never switch over to the low speed range with the selector control on the gear lever if the vehicle speed exceeds about 20 km.p.h. (12 m.p.h.).

- 9 Always reverse in the low speed range. It is absolutely forbidden to change between LOW and HIGH while reversing.

- 10 Use the exhaust brake when running downhill and for gradual braking. Operate the exhaust brake at least once a day in order to avoid sticking due to carbon deposits.

- 11 "Jack-knifing" of the trailer can be avoided by using the hand control for the trailer brake. Do not forget to return the control after braking.

- 12 Utilise the advantage provided by the differential lock when running on a slippery surface but note the following:
Never engage the differential lock if one of the wheels is already spinning. Allow the wheels to stop spinning first.
Never drive on a firm surface with the differential lock engaged.

- 13 After hard driving, allow the engine to idle for about 1 minute before stopping it in order to avoid heat stresses in the engine and loss of coolant.

- 14 Drain the condensation water from the brake reservoirs regularly — once a day during winter. Make sure that the anti-freeze container is 2/3rds filled with methylated spirit or with methanol during very cold weather.

- 15 Always use the correct fuel and lubricating oils.